

Learn Ukulele with Matt - Student Community

learnukelele.com



SCALES REFERENCE

SEPTEMBER 30, 2025

(2nd Edition, revised)

NOTES

The scales diagrams in this booklet include only those that have been used in Matt's YouTube Kanikapila live-streams from June 27, 2022 to January 29, 2025.

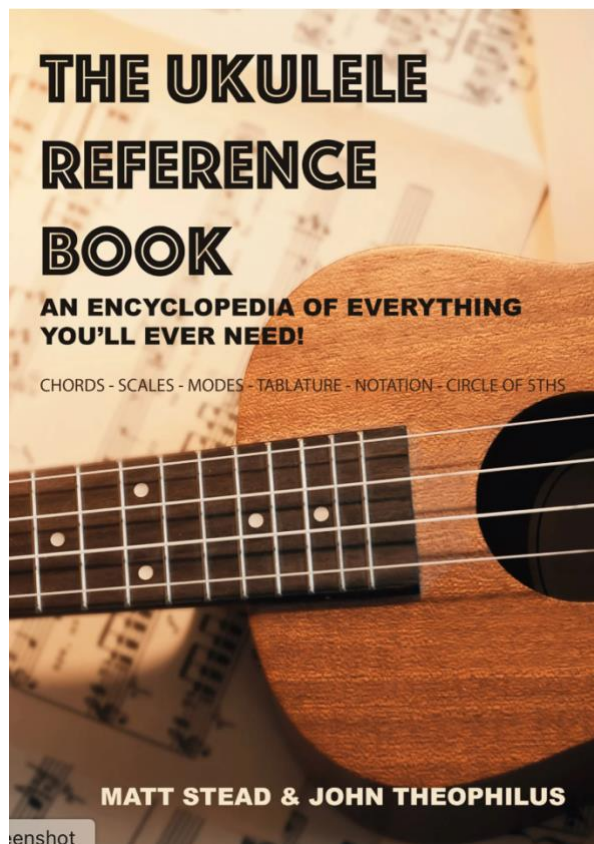

*For a more detailed explanation of chords, scales, notation, tablature, etc., please consult **The Ukulele Reference Book: An Encyclopedia of Everything You'll Ever Need**, (2021) by Matt Stead and John Theophilus. Available for purchase (digital download) from*

<https://payhip.com/b/vdpaU>

Fretboard diagrams in this Kanikapila booklet were created in NeckDiagrams software by Karen Morrow for Matt Stead

New in this edition: *F Major, E melodic minor, key signatures, minor scales chart*

TABLE OF CONTENTS

DO-IT-YOURSELF SCALES.....5

MOST COMMON SCALE PATTERNS.....6

MAJOR SCALES9

 C Major9

 D Major.....10

 F Major11

 G Major.....12

 A Major.....13

PENTATONIC SCALES14

 A minor pentatonic15

 C Major Pentatonic.....16

 D Major Pentatonic17

 B minor Pentatonic.....18

 D minor / F major pentatonic.....19

 E minor / G Major Pentatonic20

 F minor / A \flat Major Pentatonic.....21

 F# Minor / A Major Pentatonic22

MELODIC MINOR SCALES.....23

 E Melodic Minor23

BLUES SCALES.....24

C Blues..... 24

G Blues..... 25

F# minor Blues / A Major Blues..... 26

CIRCLE OF FIFTHS..... 27

KEY SIGNATURES..... 28

MAJOR SCALES CHART..... 29

MINOR SCALES CHART..... 30

LEARN UKULELE WITH MATT..... 32



DO-IT-YOURSELF SCALES

Choose a note to start on, then let your fingers follow the chart to climb up the scale. For example, you could start to build a C major scale starting on the C string, or you may choose to start on the A string. For a G major scale you could start on the E string, or the C string. You could choose to play the notes of a scale all on one string, or travel across the strings. It's up to you!

Note that once you reach the 12th fret, the chart diagram repeats itself. Your ukulele may have anywhere from 12 to 20 frets, depending on whether it's a soprano, concert or tenor size.

*Sharps and flats (accidentals) are not noted on this chart for the sake of legibility. See the major and minor scale charts (pgs. 29 & 30) to determine which scales require accidentals.

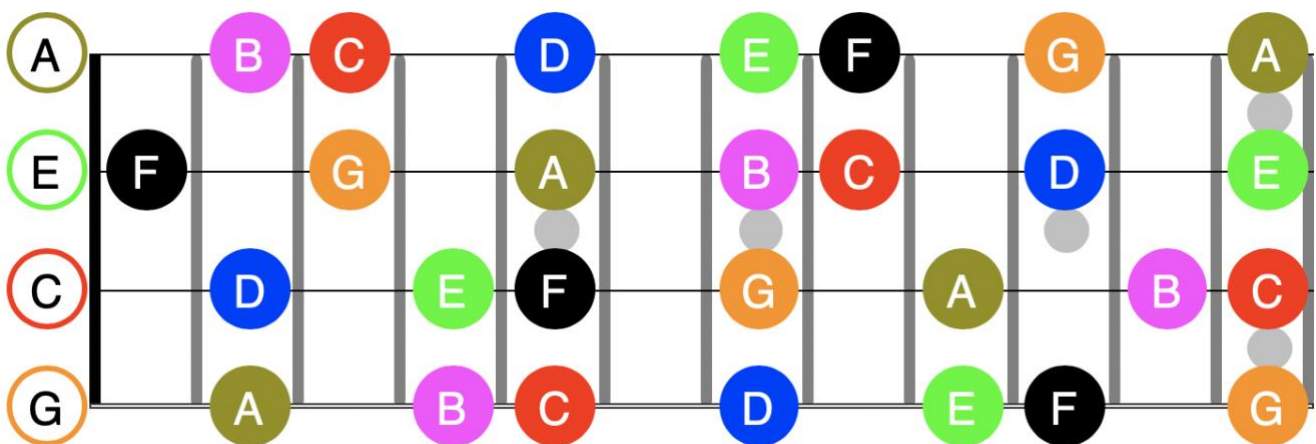

MOST COMMON SCALE PATTERNS

(Numbered by Scale Degree)

BUILDING A MAJOR SCALE

 = Root note

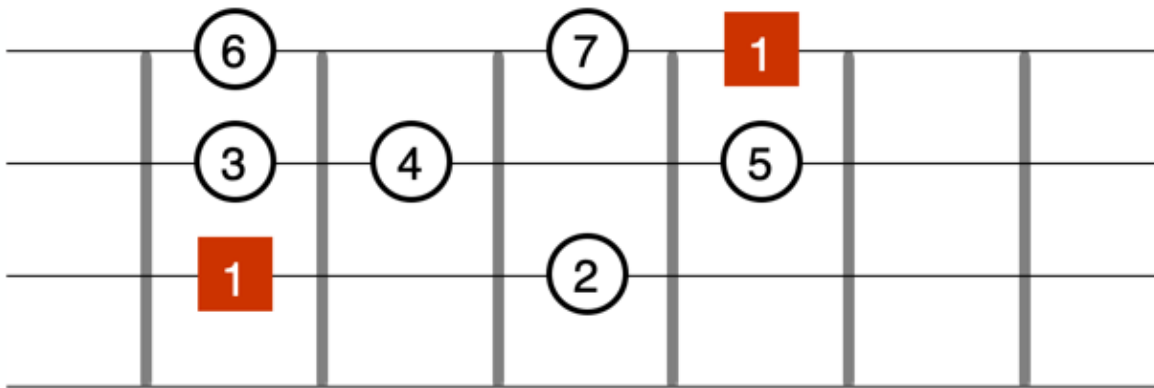

BUILDING A (NATURAL) MINOR SCALE

 = Root note

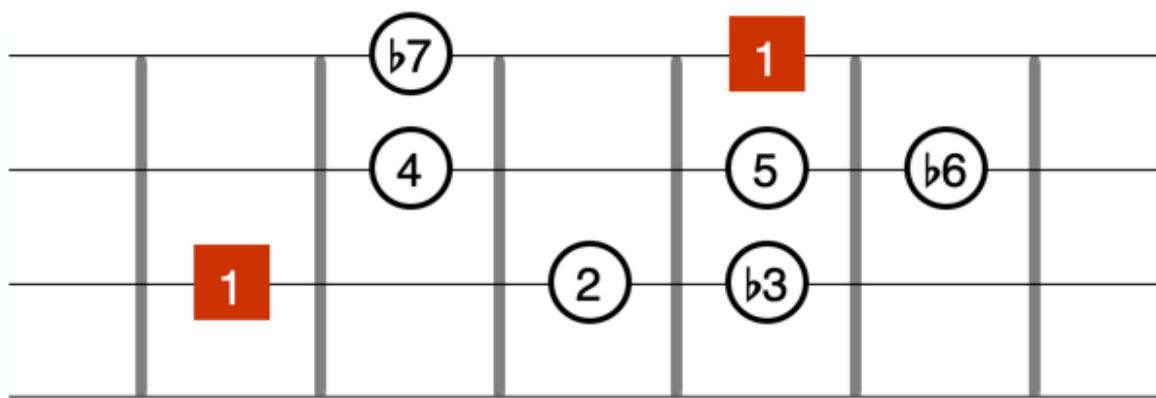

BUILDING A MELODIC MINOR

 = Root note

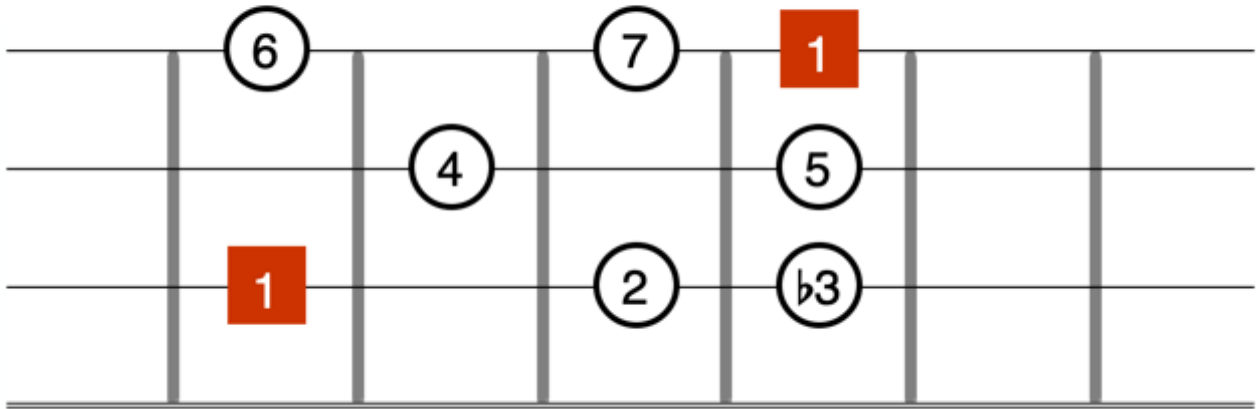

BUILDING A BLUES SCALE

 = Blues Note

 = Root note

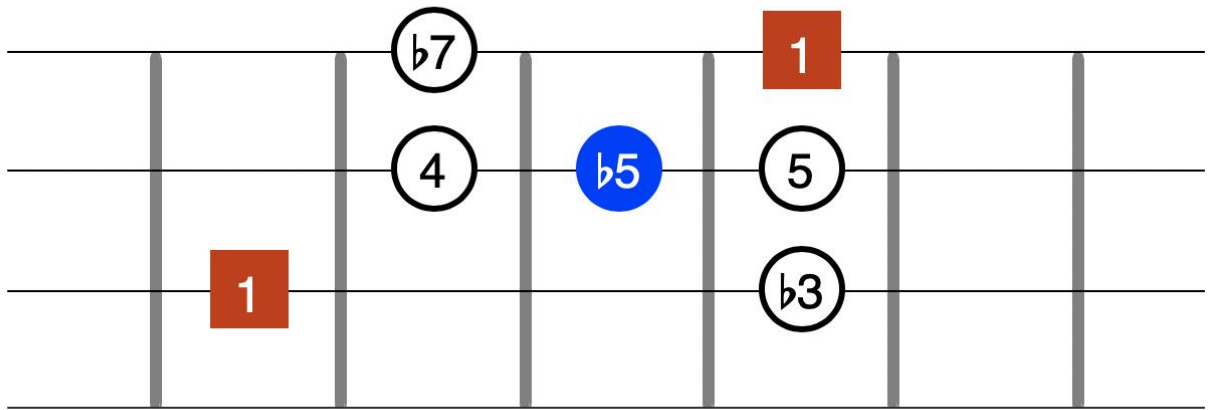

BUILDING A PENTATONIC SCALE

Start your scale on any fret, then climb the scale playing the notes in the order indicated. Does the major pentatonic sound familiar? Think of the guitar riff from "My Girl" by The Temptations.

MAJOR PENTATONIC

 = Root note

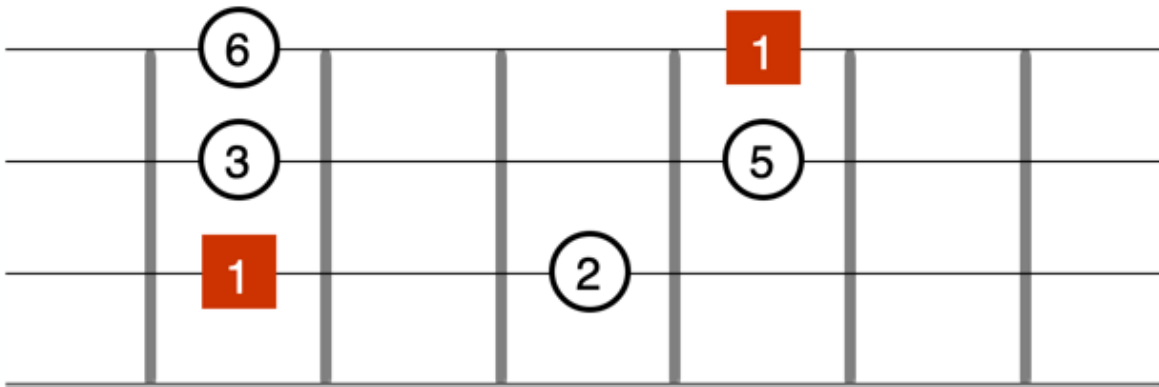



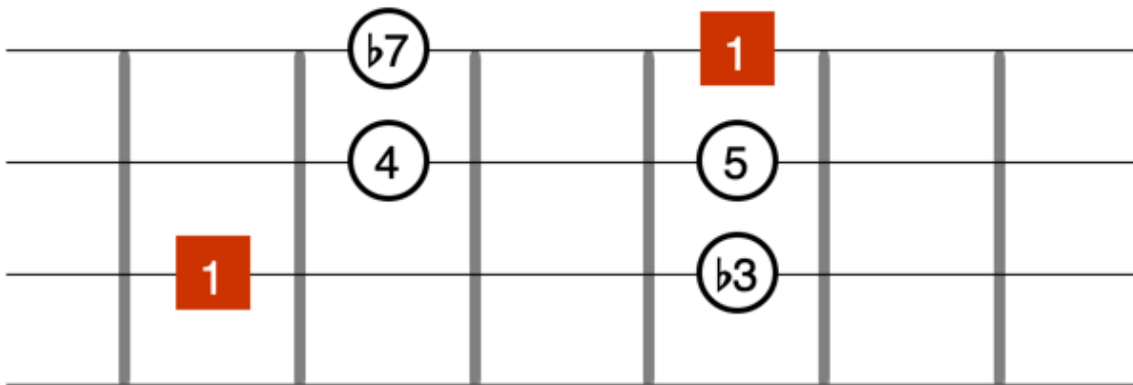

MINOR PENTATONIC

 = Root note



MAJOR SCALES

			
Blues note	Open string	Root note on open string	Root note



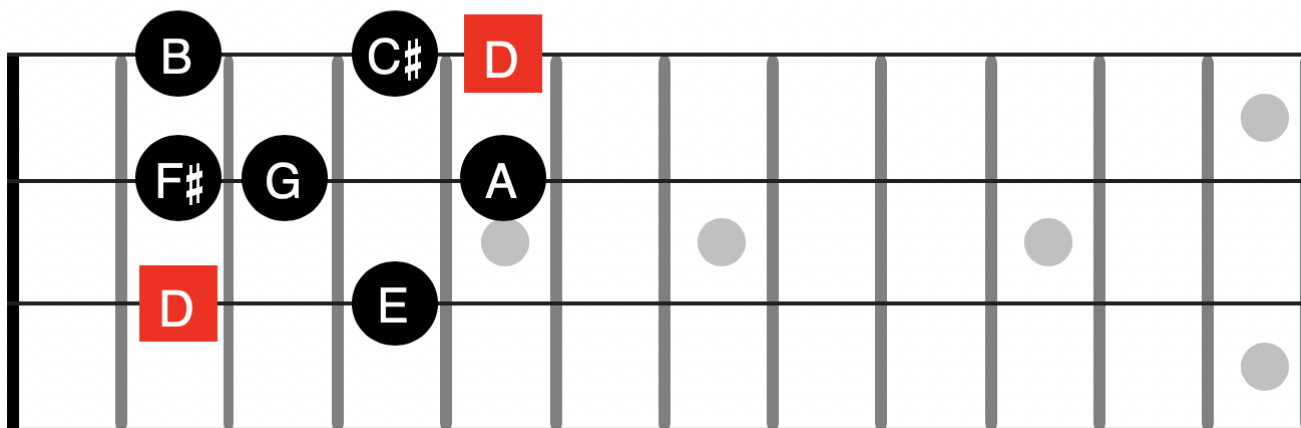

D MAJOR - SIMPLIFIED

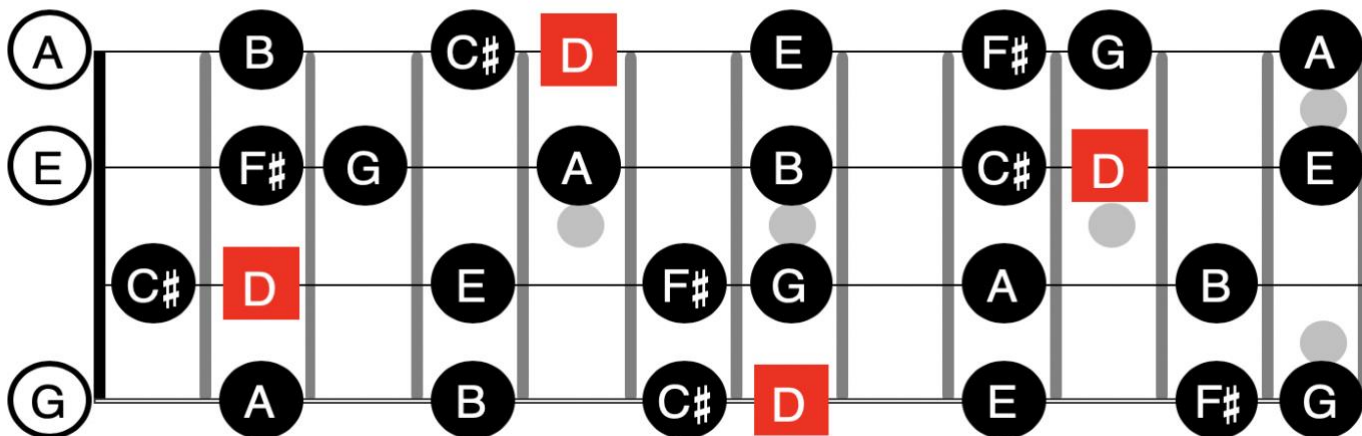

D MAJOR - ALL PLAYING OPTIONS



MAJOR SCALES

			
Blues note	open string	Root note on open string	Root note



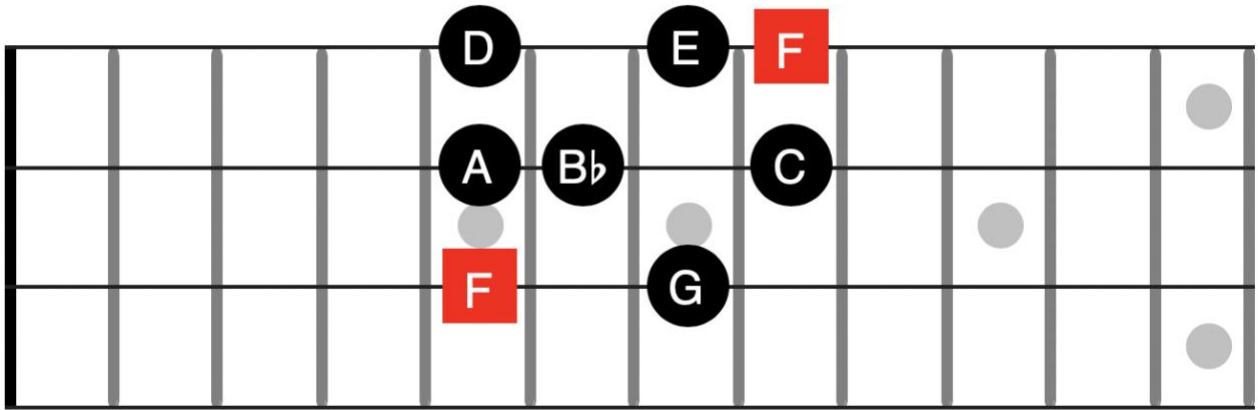

F MAJOR - SIMPLIFIED

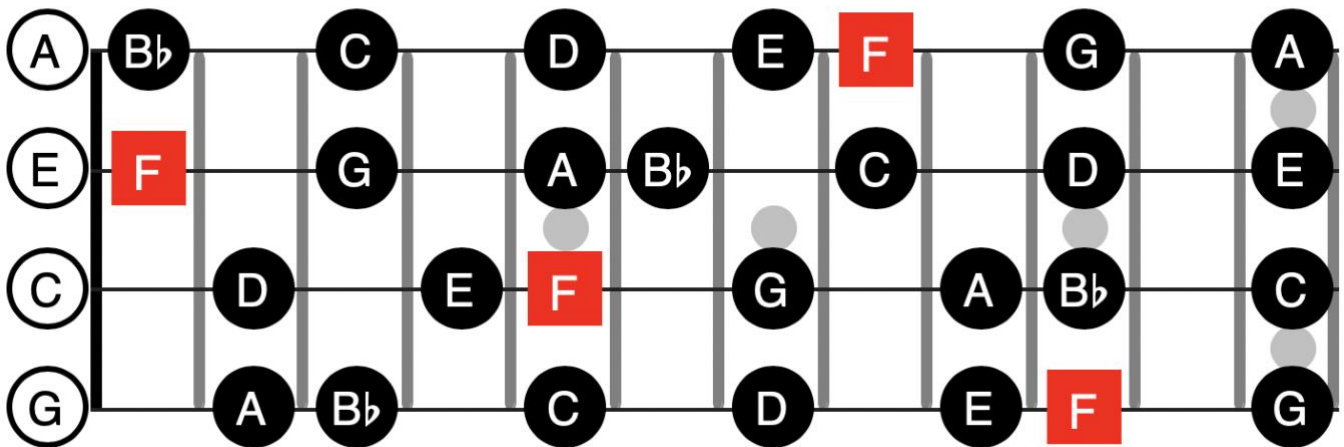

F MAJOR - ALL PLAYING OPTIONS



MAJOR SCALES

			
Blues note	open string	Root note on open string	Root note



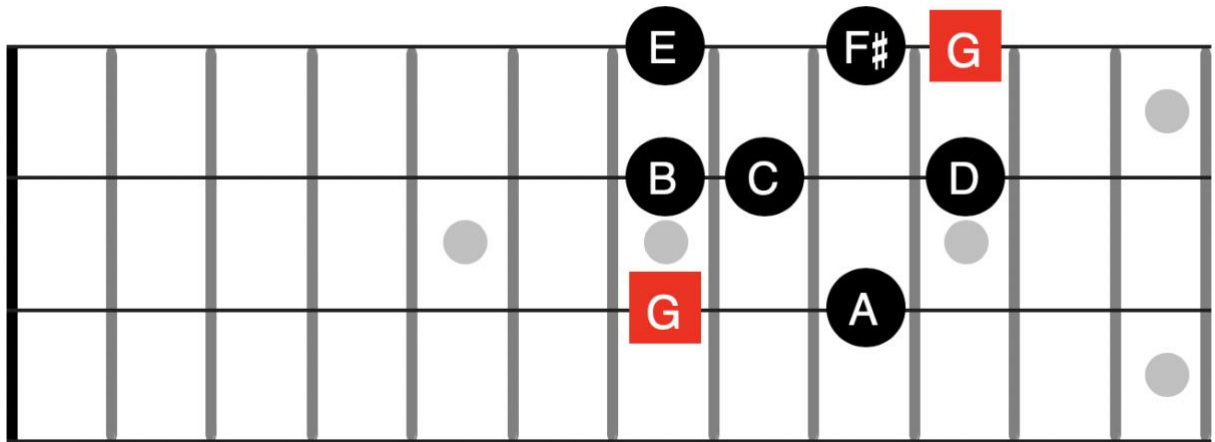

G MAJOR - SIMPLIFIED

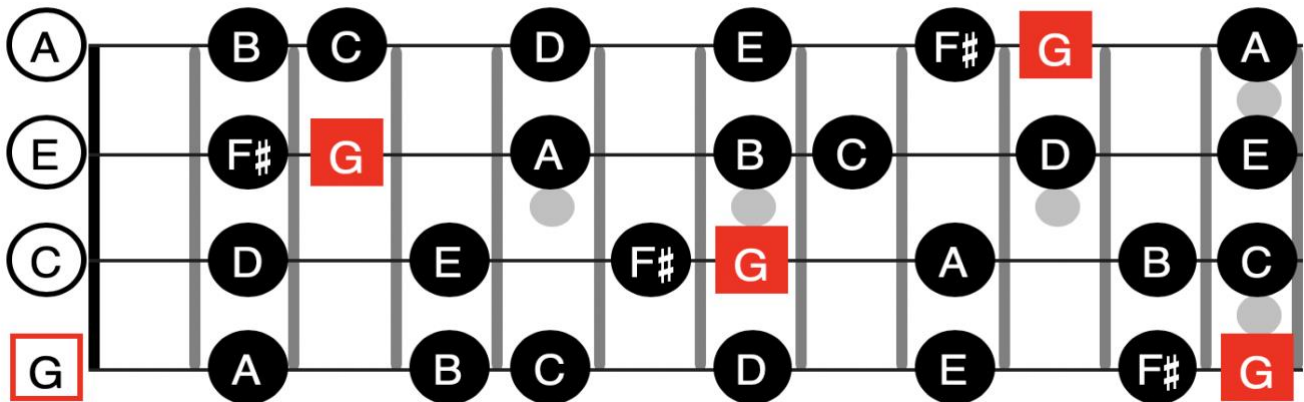

G MAJOR - ALL PLAYING OPTIONS



MAJOR SCALES

			
Blues note	Open string	Root note on open string	Root note

A MAJOR - SIMPLIFIED

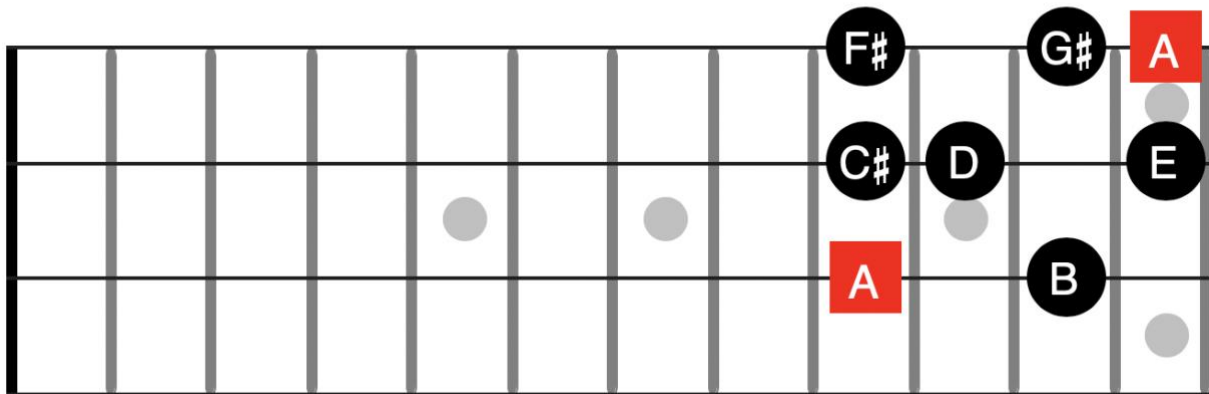

A MAJOR - ALL PLAYING OPTIONS

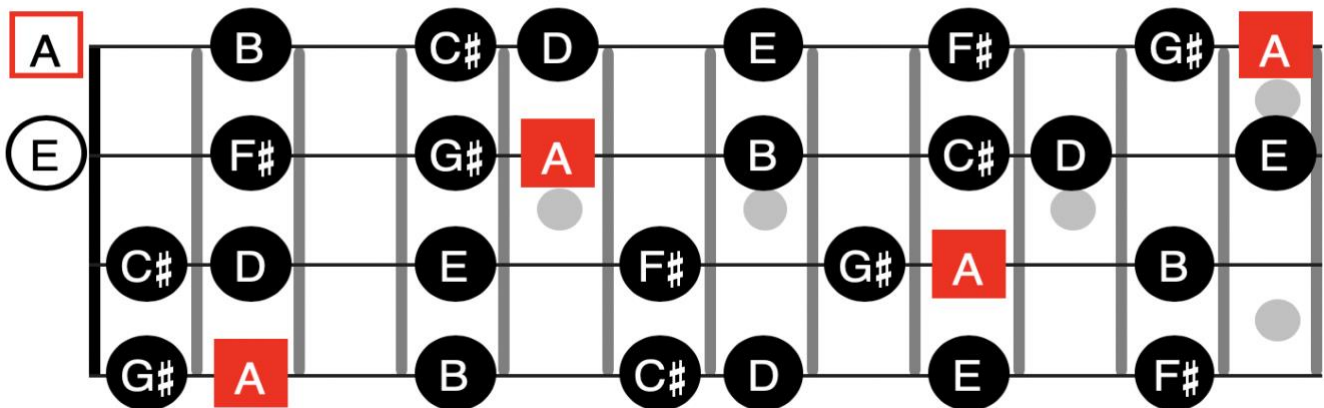

PENTATONIC SCALES

A pentatonic scale is a major or minor scale with the half steps (a/k/a half tones) removed. For example:

MAJOR PENTATONIC:

The C major scale:

1	2	3	4	5	6	7
C	D	E	F	G	A	B

Remove 4th and 7th notes to get



The C major pentatonic scale:

1	2	3	5	6
C	D	E	G	A

MINOR PENTATONIC:

The A minor scale:

1	2	3	4	5	6	7
A	B	C	D	E	F	G





Remove 2nd and 6th notes to get



The A minor pentatonic scale:

1	3	4	5	7
A	C	D	E	G

PENTATONIC SCALES

			
Blues note	open string	Root note on open string	Root note

Soloing tip To create a simple A minor pentatonic solo, use the dots on the A string for reference. Also use the dots on the E string but skip the 7th fret and play the 8th fret instead. You can also jump between the two strings to create your solo.



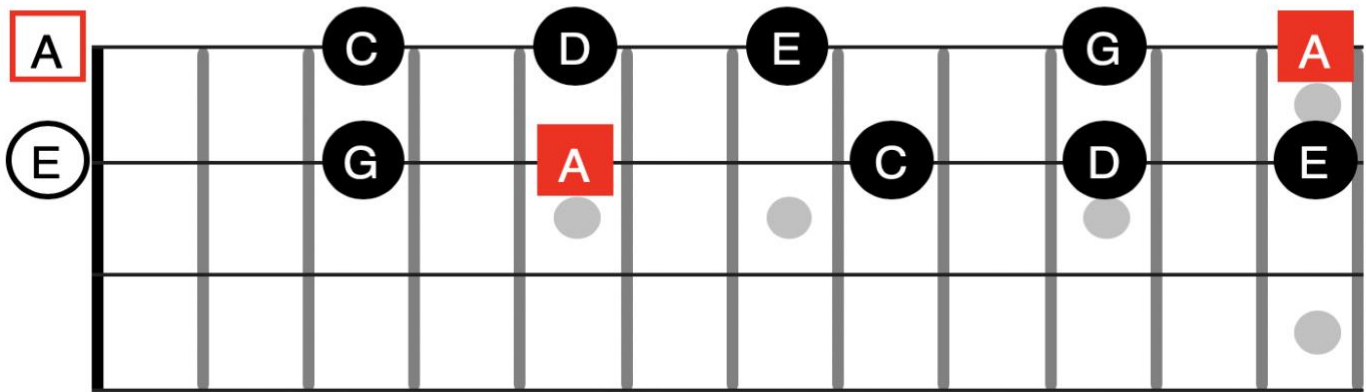

A MINOR PENTATONIC - SIMPLIFIED

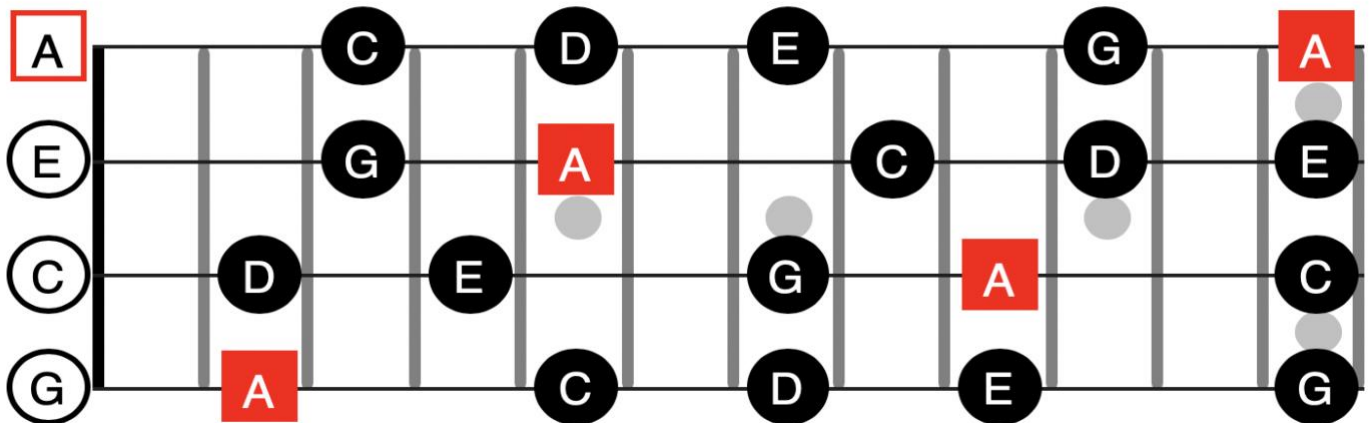

A MINOR PENTATONIC - ALL PLAYING OPTIONS



PENTATONIC SCALES

			
Blues note	open string	Root note on open string	Root note



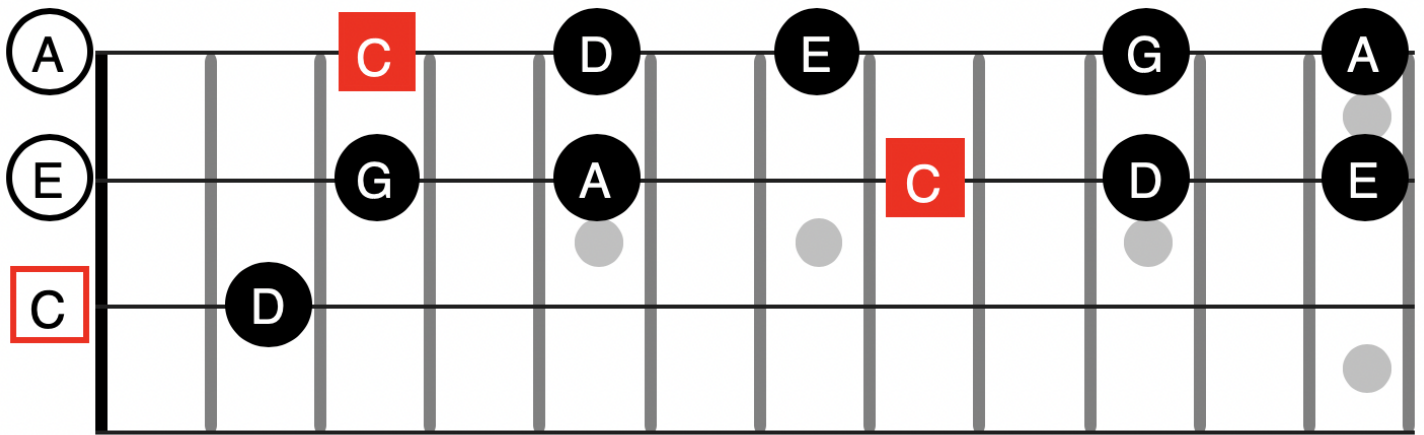

C MAJOR PENTATONIC - SIMPLIFIED

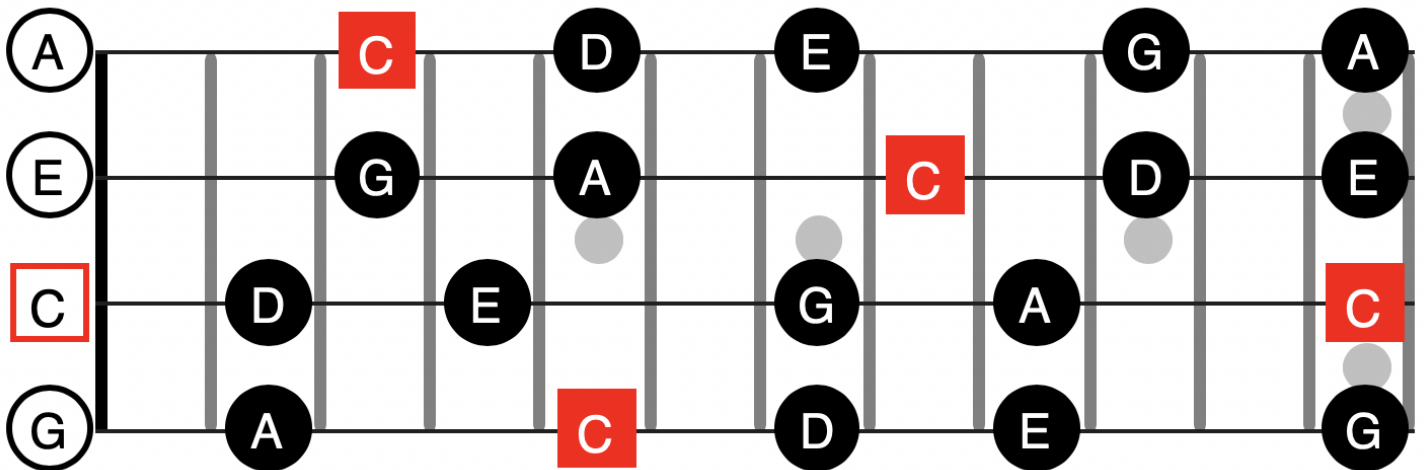

C MAJOR PENTATONIC - ALL PLAYING OPTIONS



PENTATONIC SCALES

			
Blues note	Open string	Root note on open string	Root note



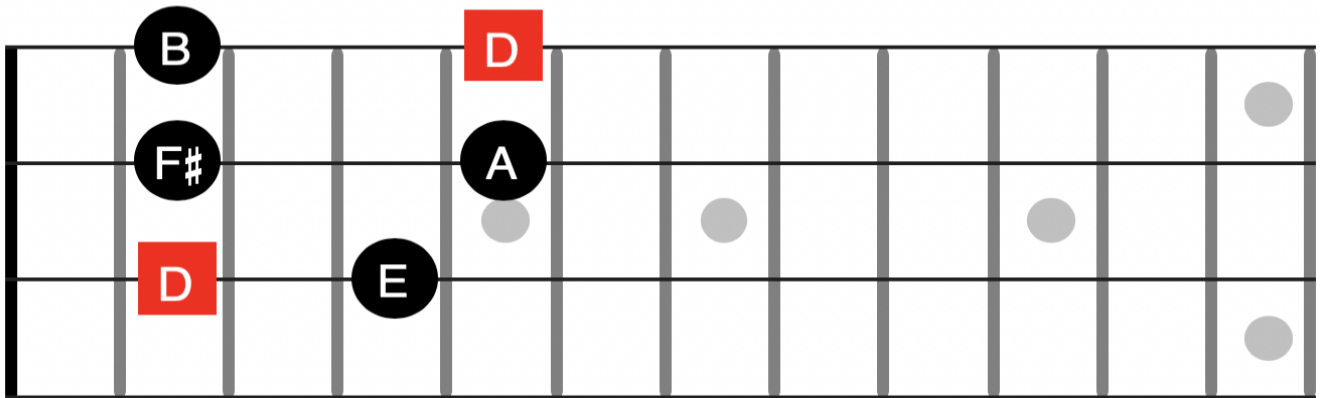

D MAJOR PENTATONIC - SIMPLIFIED

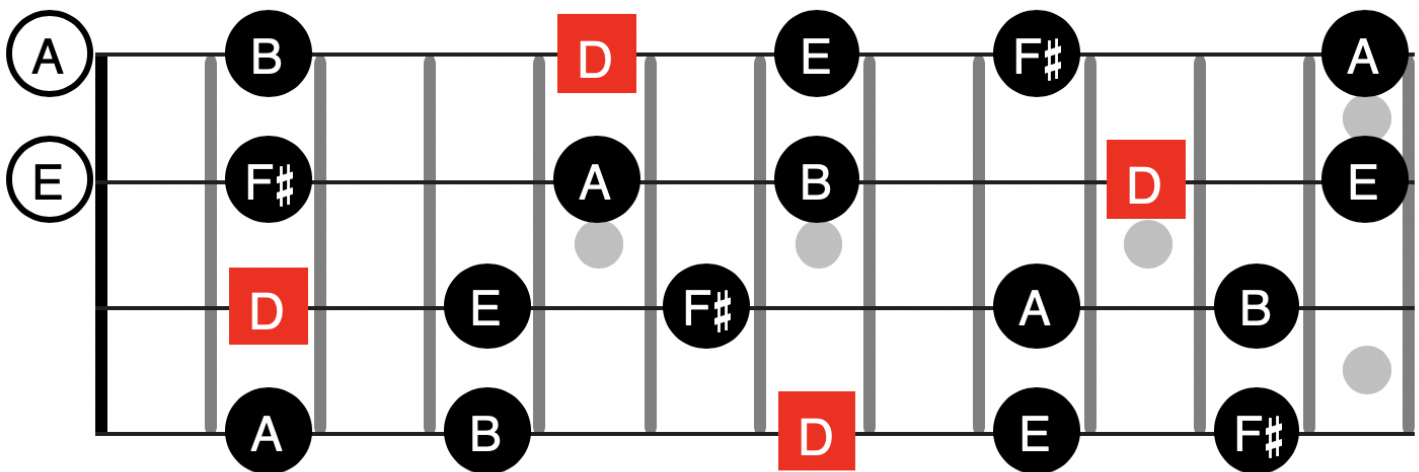

D MAJOR PENTATONIC - ALL PLAYING OPTIONS



PENTATONIC SCALES

			
Blues note	open string	Root note on open string	Root note



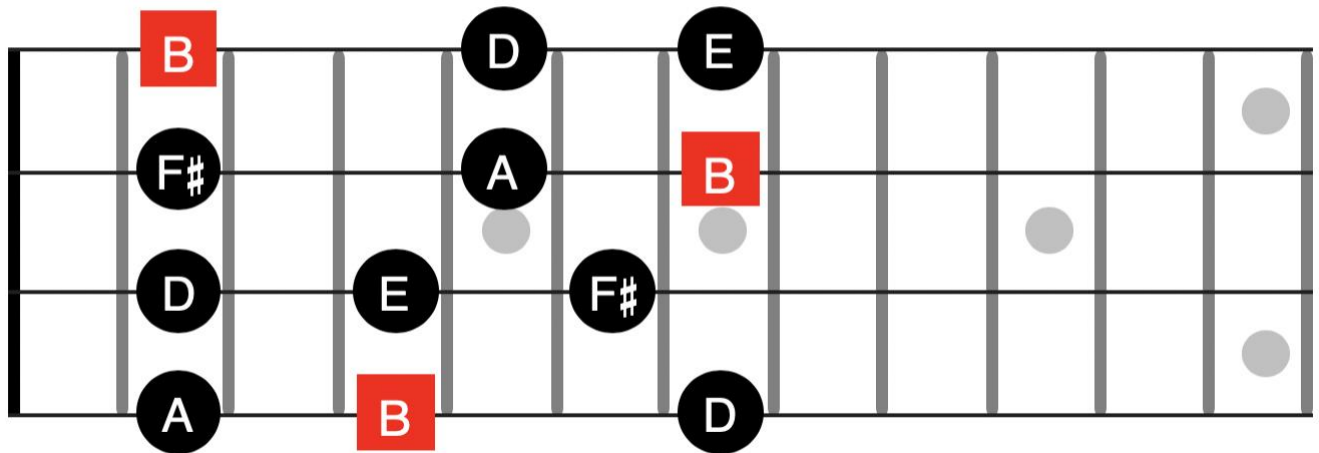

B MINOR PENTATONIC - SIMPLIFIED

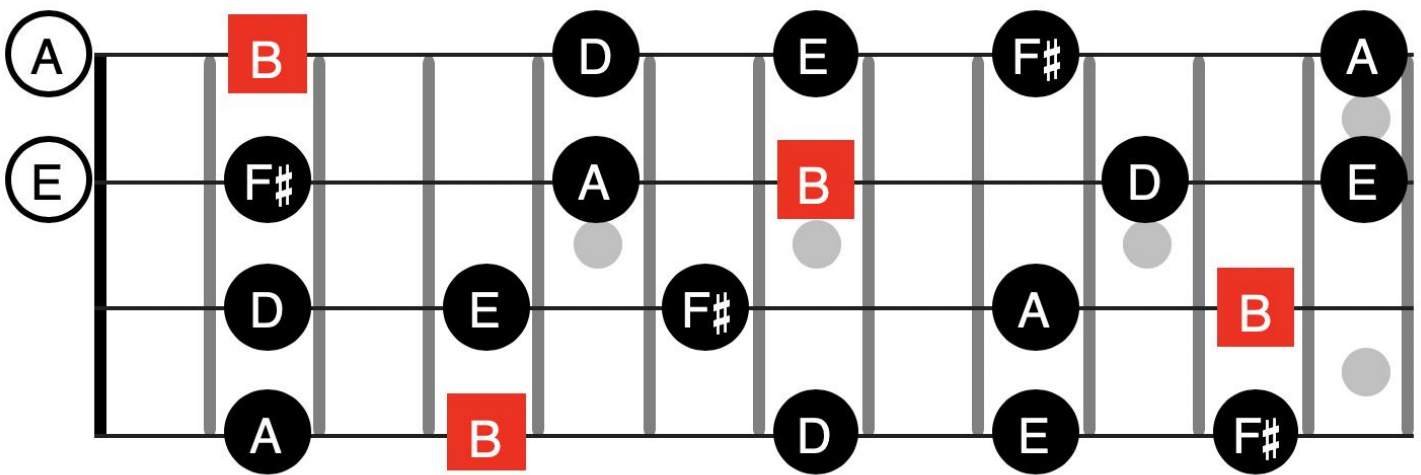

B MINOR PENTATONIC - ALL PLAYING OPTIONS



PENTATONIC SCALES

			
Blues note	open string	Root note on open string	Root note

D MINOR PENTATONIC - SIMPLIFIED

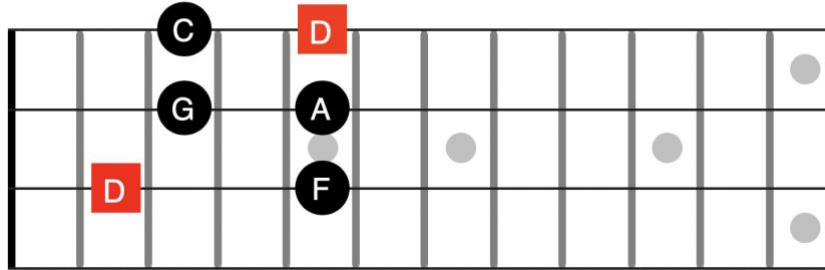

F MAJOR PENTATONIC - SIMPLIFIED

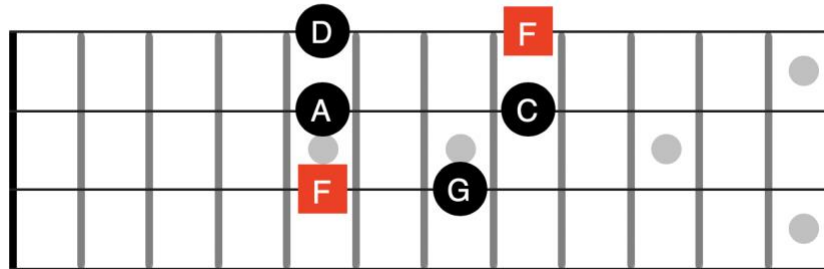



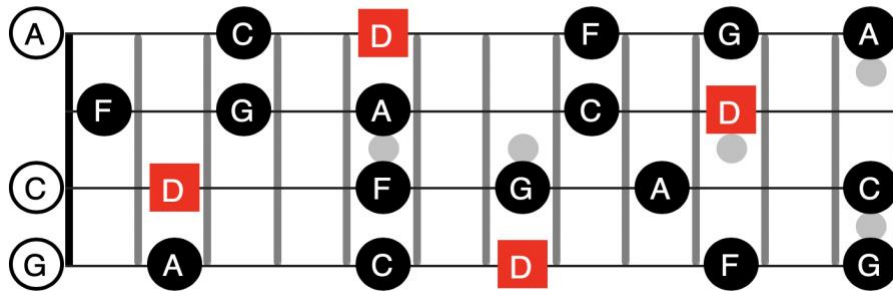

D MINOR PENTATONIC - ALL PLAYING OPTIONS

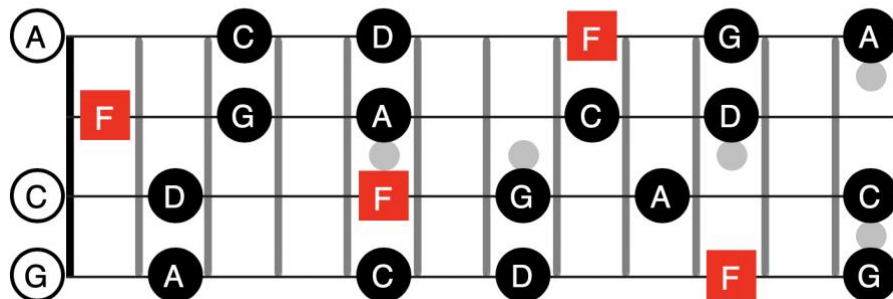

F MAJOR PENTATONIC - ALL PLAYING OPTIONS



PENTATONIC SCALES

			
Blues note	open string	Root note on open string	Root note

E MINOR PENTATONIC - SIMPLIFIED

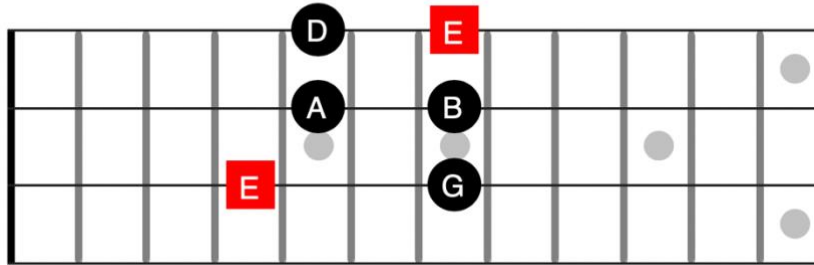

G MAJOR PENTATONIC - SIMPLIFIED

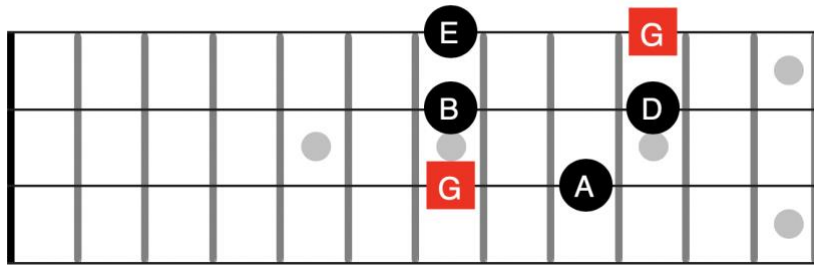



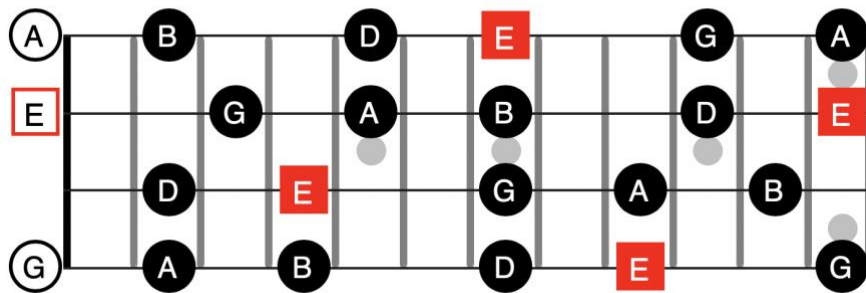

E MINOR PENTATONIC - ALL PLAYING OPTIONS

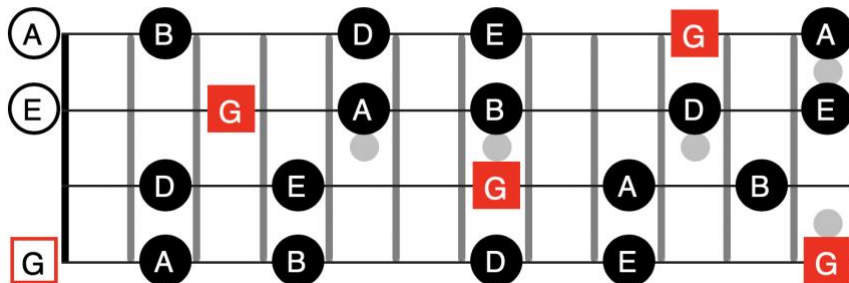

G MAJOR PENTATONIC - ALL PLAYING OPTIONS



PENTATONIC SCALES

			
Blues note	open string	Root note on open string	Root note

F MINOR PENTATONIC - SIMPLIFIED

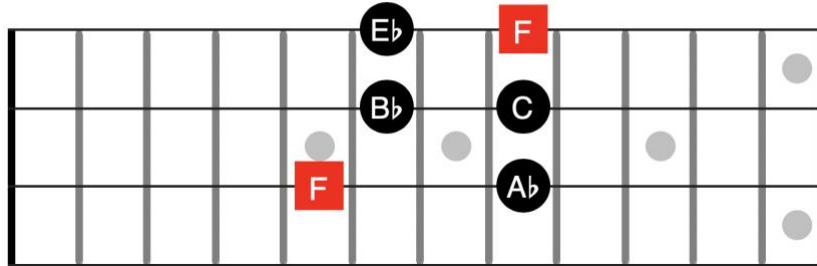

A \flat MAJOR PENTATONIC - SIMPLIFIED

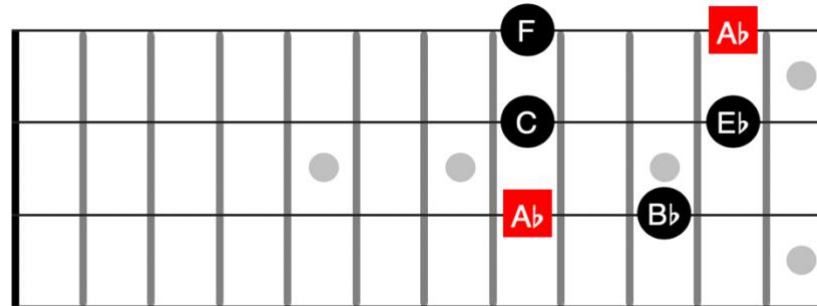



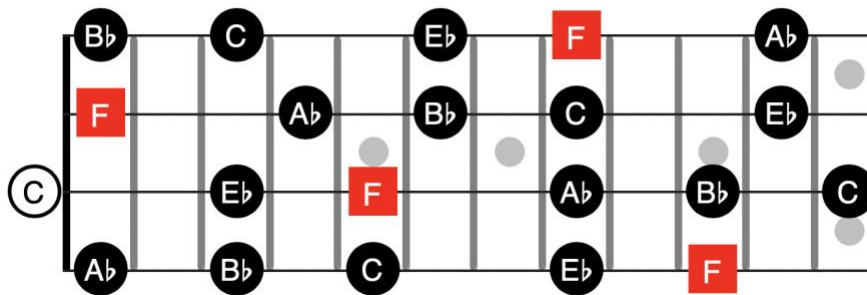

F MINOR PENTATONIC - ALL PLAYING OPTIONS

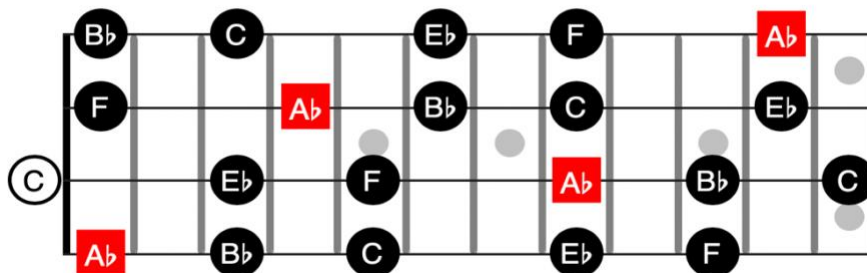

A \flat MAJOR PENTATONIC - ALL PLAYING OPTIONS



PENTATONIC SCALES

			
Blues note	open string	Root note on open string	Root note

F# MINOR PENTATONIC - SIMPLIFIED

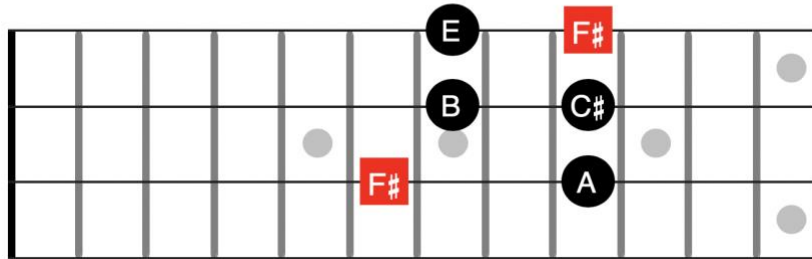

A MAJOR PENTATONIC - SIMPLIFIED

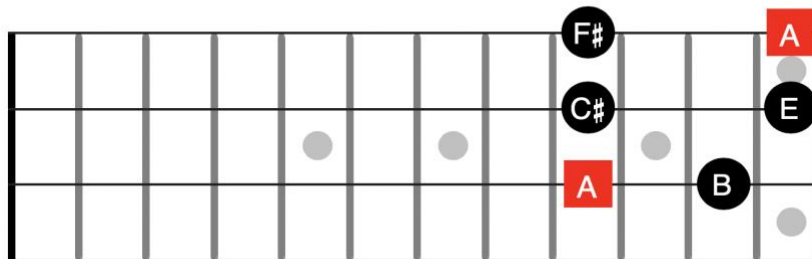



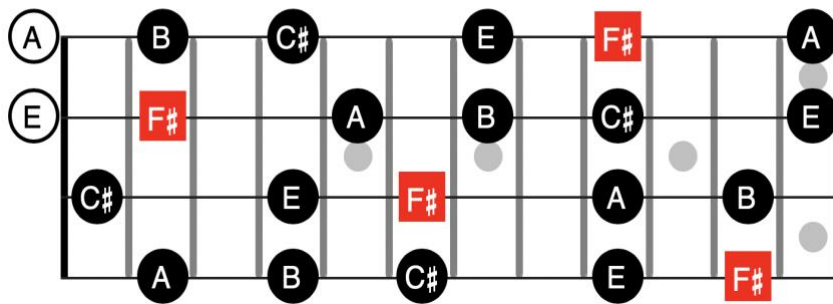

F# MINOR PENTATONIC - ALL PLAYING OPTIONS

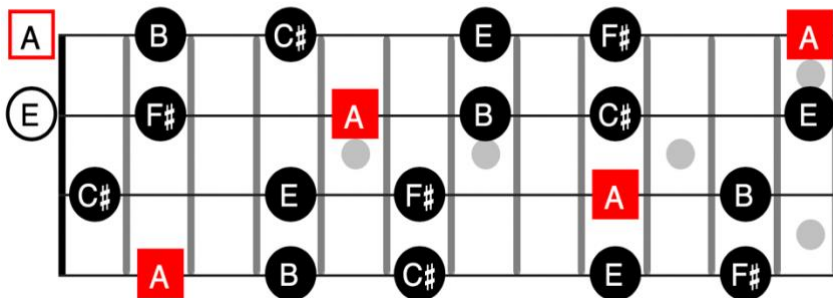

A MAJOR PENTATONIC - ALL PLAYING OPTIONS



MELODIC MINOR SCALES

			
Blues note	open string	Root note on open string	Root note

E MELODIC MINOR - SIMPLIFIED

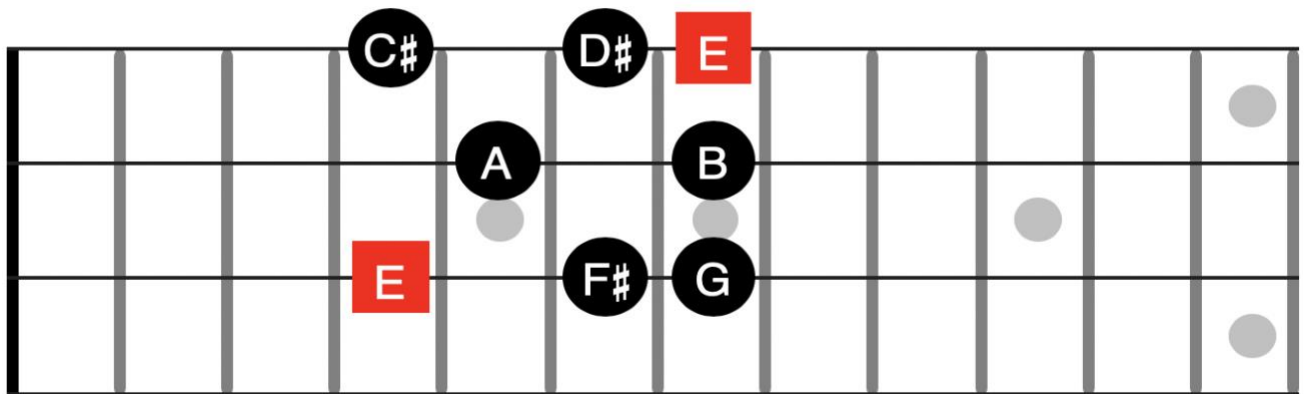



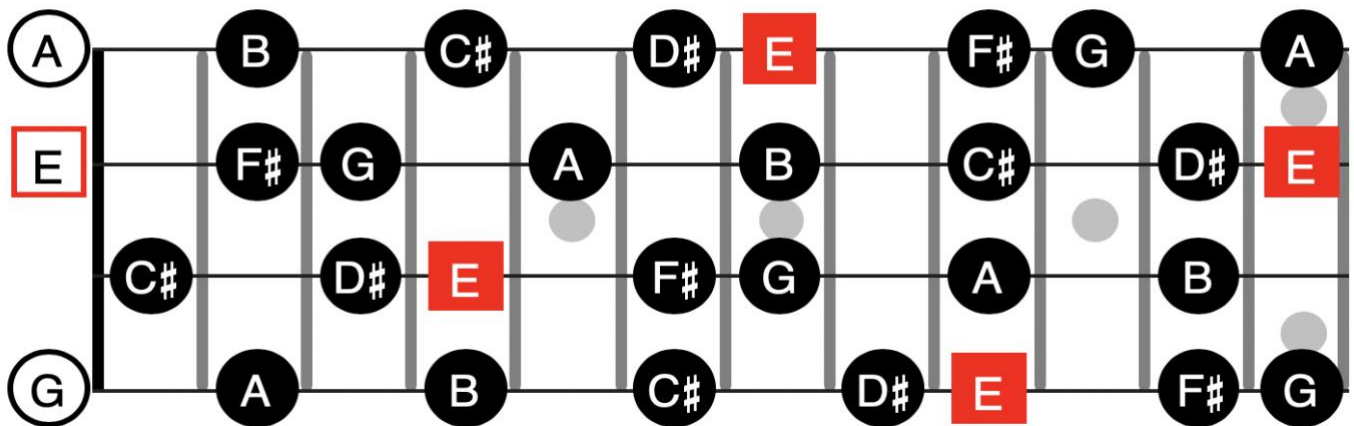

E MELODIC MINOR - ALL PLAYING OPTIONS



BLUES SCALES

The Blues scale is built on the minor pentatonic scale, with the addition of a flatted 5th note, or "blues note".

			
Blues note	Open string	Root note on open string	Root note



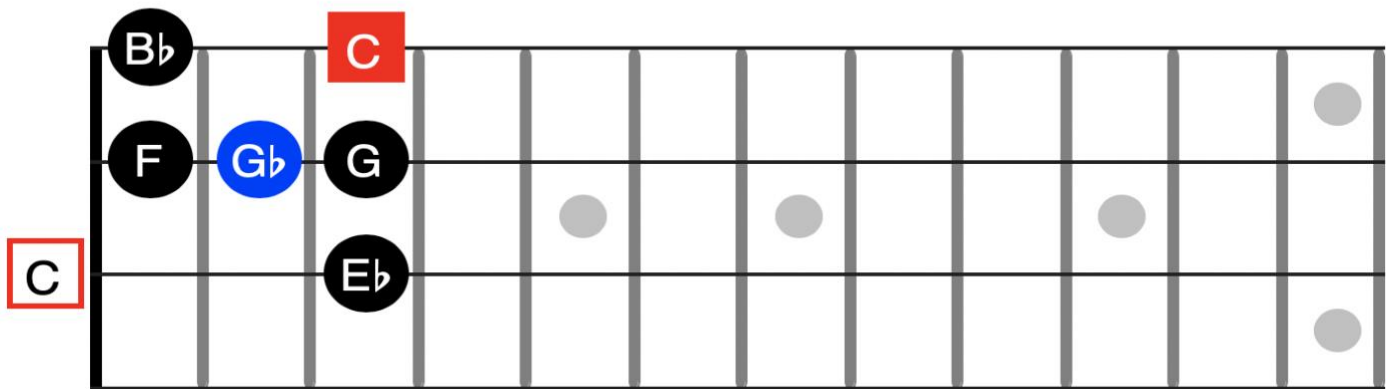

C BLUES - SIMPLIFIED

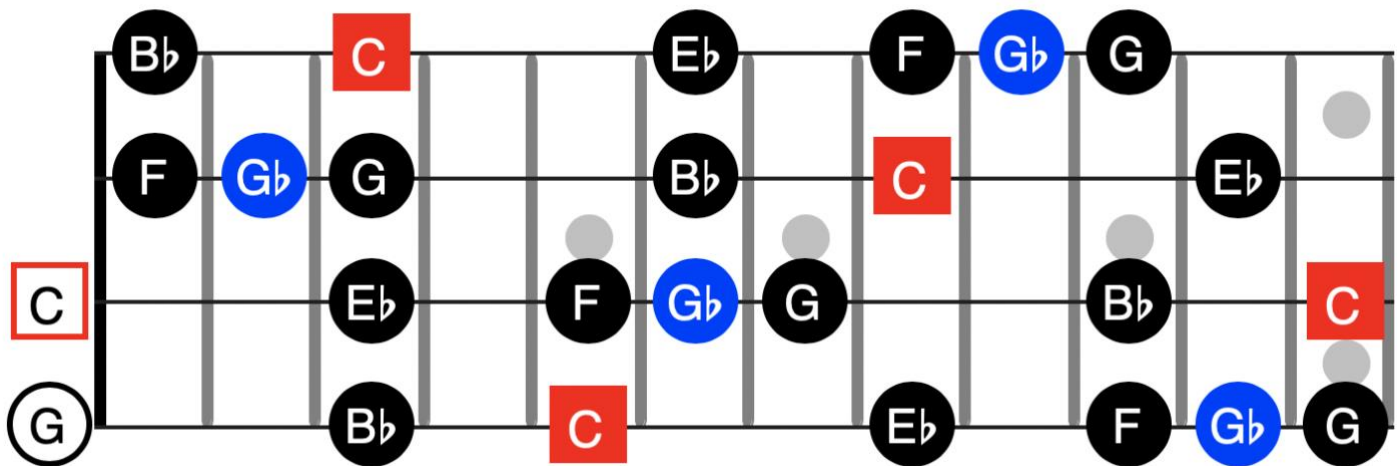

C BLUES - ALL PLAYING OPTIONS



BLUES SCALES

			
Blues note	open string	Root note on open string	Root note



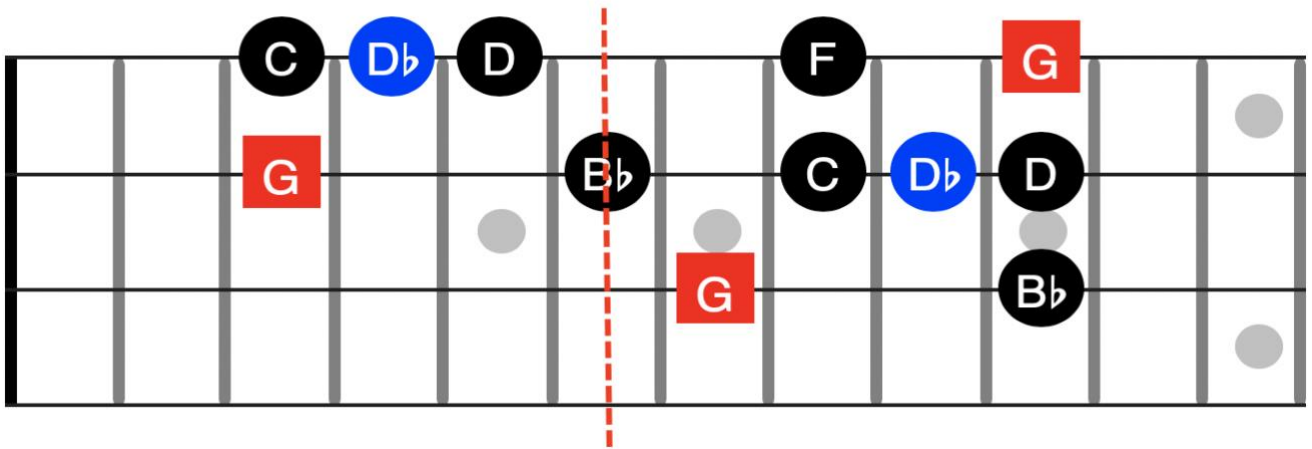

G BLUES - SIMPLIFIED

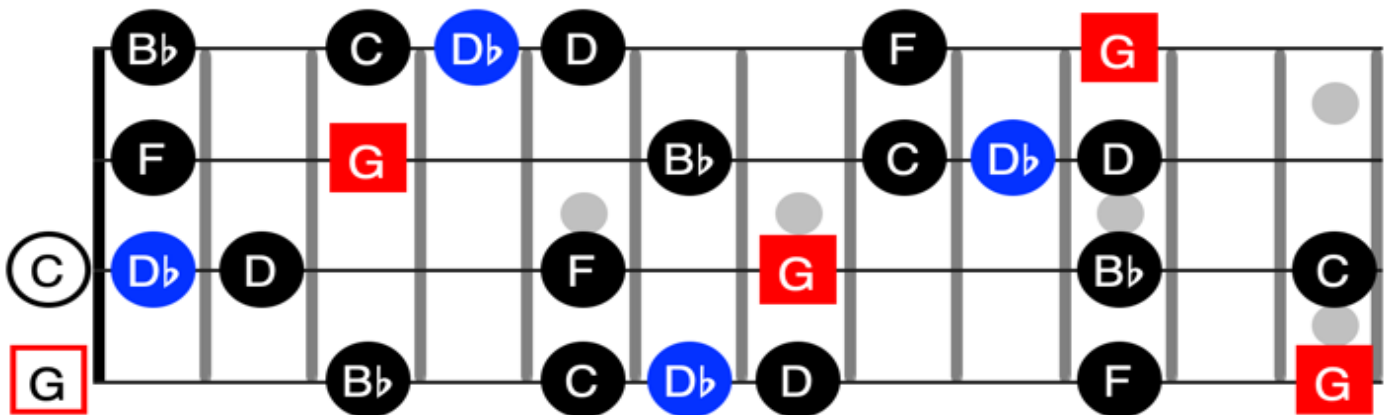

G BLUES - ALL PLAYING OPTIONS



BLUES SCALES

			
Blues note	Open string	Root note on open string	Root note

F# MINOR BLUES | A MAJOR BLUES - SIMPLIFIED

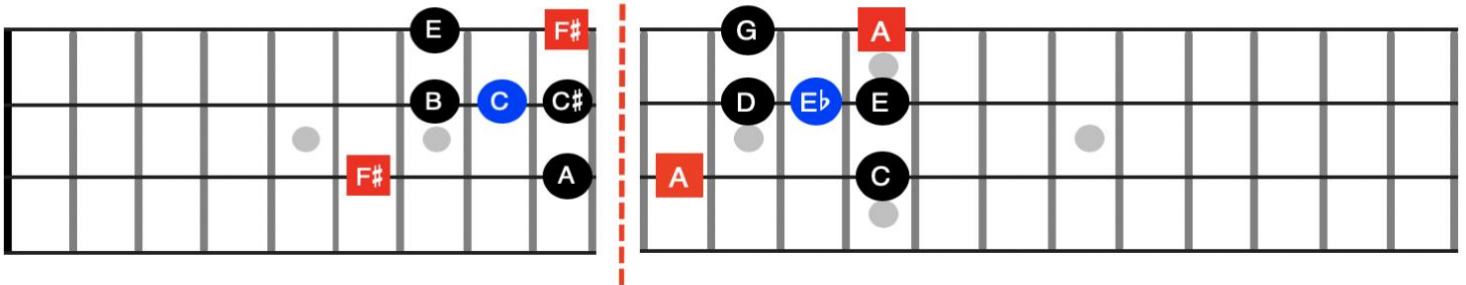

F# MINOR BLUES - ALL PLAYING OPTIONS

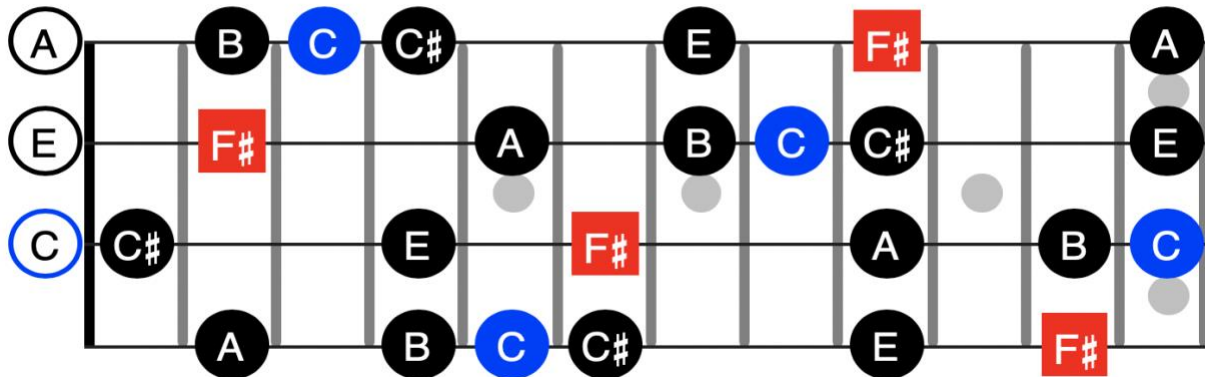

A MAJOR BLUES - ALL PLAYING OPTIONS

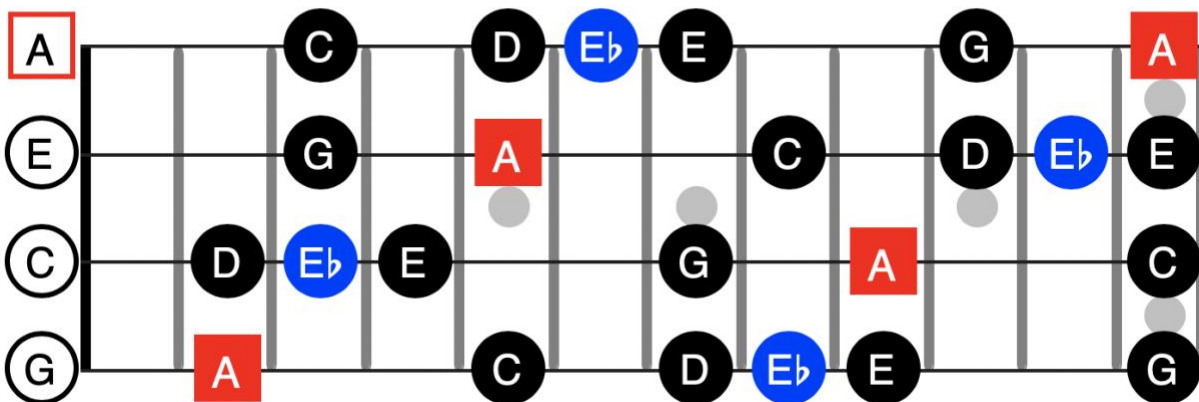

CIRCLE OF FIFTHS

For a lesson on how to use the Circle of Fifths see of [Matt's Uke Theory and Beyond Beginners: Intermediate Ukulele](#) courses on www.learnukulele.com.

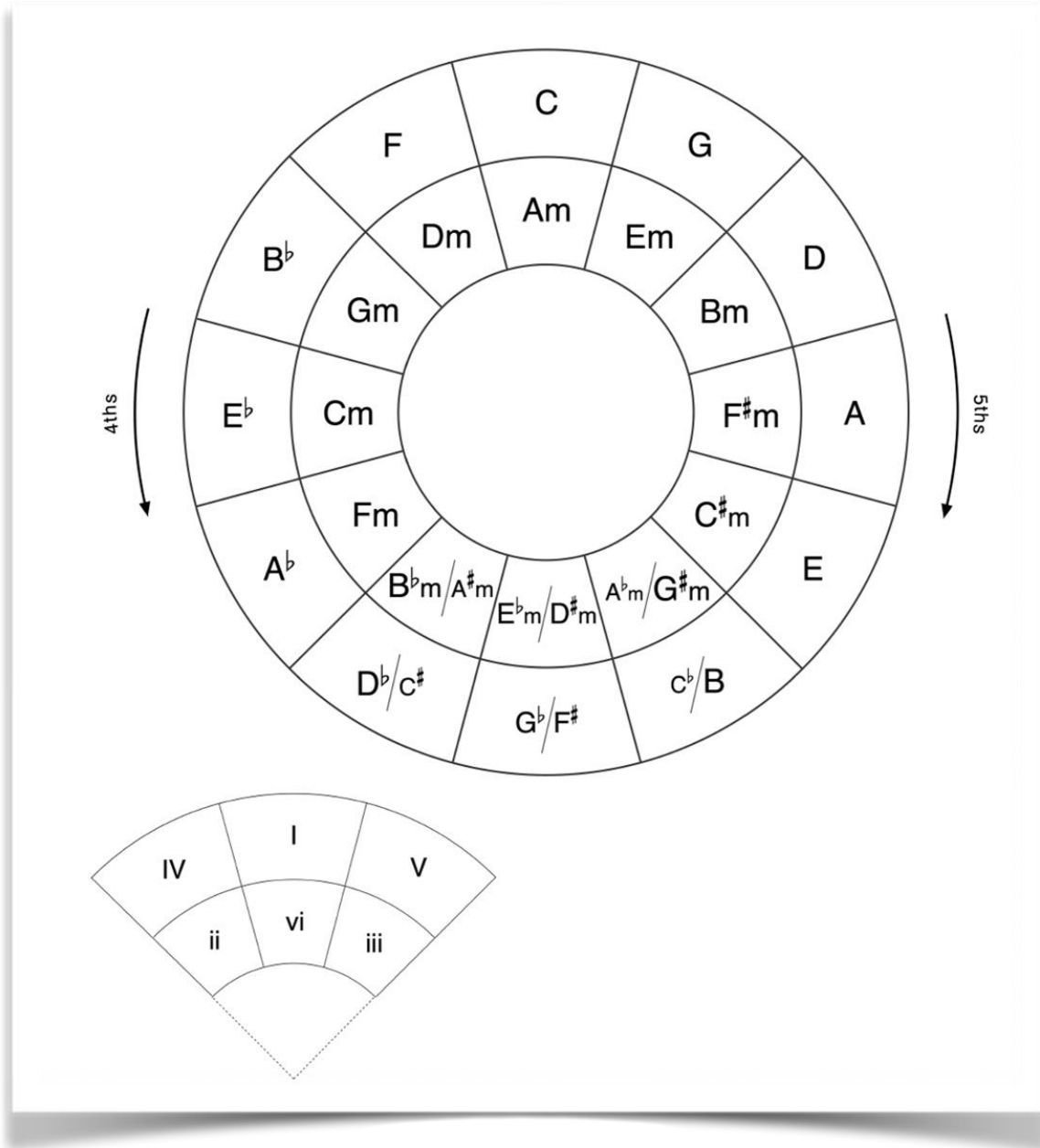

KEY SIGNATURES

These are the most common key signatures used in [Matt's Kanikapila YouTube sessions](#).



MAJOR SCALES CHART

For a lesson on how to use this chart and/or the Circle of Fifths to transpose a song from one key to another, see [Matt's Uke Theory and Beyond Beginners: Intermediate Ukulele](#) courses on www.learnukulele.com. This chart is not comprehensive and includes only the most commonly used keys in Matt's Kanikapila sessions on YouTube.

	ROMAN NUMERALS						
	MAJOR	minor	minor	MAJOR	MAJOR	minor	diminished
	I	ii	iii	IV	V	vi	vii ^o
-	C	Dm	Em	F	G	Am	B dim
#	G	Am	Bm	C	D	Em	F# dim
b	F	Gm	Am	B _b	C	Dm	E dim
###	A	Bm	C#m	D	E	F#m	G# dim
##	D	Em	F#m	G	A	Bm	C# dim
bb	B _b	Cm	Dm	E _b	F	Gm	A dim

Symbols you should know :

- b = flat
- # = sharp
- o = diminished
- Δ = Major 7th
- + = augmented
- sus = suspended

MINOR SCALES CHART

(Natural Minor)

	ROMAN NUMERALS						
	minor	diminished	MAJOR	minor	minor	MAJOR	MAJOR
	i	ii°	III	iv	v	VI	VII
bbb	Cm	D dim	E _b	Fm	Gm	A _b	B _b
bb	Gm	A dim	B _b	Cm	Dm	E _b	F
bbbb	Fm	G dim	A _b	B _b m	Cm	D _b	E _b
-	Am	B dim	C	Dm	Em	F	G
b	Dm	E dim	F	Gm	Am	B _b	C
bbbbb	B _b m	C dim	D _b	E _b m	Fm	G _b	A _b

Roman Numerals vs. Nashville Numbers – What’s the Difference?

There are two systems of chord notation that are commonly used: the Nashville Number System and Roman Numeral Analysis. The two are often confused and referred to interchangeably. They are similar in function, but different in how they are notated. Both are useful in transposing music from one key to another, without having to know how to read music notation.

Roman Numeral Analysis uses a combination of capitalized and lowercase numerals to indicate a chord’s function: uppercase for a major chord and lowercase for a minor or diminished 7th chord. (See the charts on this and the previous page).

The Nashville Number System was devised by experienced session musicians in Nashville, Tennessee, USA. This system uses Arabic numbers to identify the chord position on a given scale: 1, 2, 3, 4, 5, 6, 7. There is no obvious indication of the chord quality – major, minor, or diminished – that each number represents. If the Nashville numbers are written down, other symbols would be added to indicate the quality. For example, in the C major scale, an m or – denotes a minor chord (C-, Cm), and 4Δ7 would be an Fmajor 7th chord.

eg. Nashville numbers for the chords in the C major scale:

1	2	3	4	5	6	7
C	D	E	F	G	A	B

It is assumed that the musician using this system is familiar with scales and the chord family associated with each scale. All a band leader would have to tell his players is what key the song is in, and the chord progression to use, eg. “Key of C major, I IV, V progression.”

Matt uses Roman Numeral Analysis in his Kanikapila sessions as it is more detailed and provides more useful information to new and experienced players alike.

LEARN UKULELE WITH MATT



*Join Matt Stead's online community
and learn ukulele the FUN way at
<http://www.learnukulele.com/>*

and

 *Learn Ukulele with Matt – Student Community*

Many structured sequential courses - Beginners to Advanced

Record your progress and send Matt videos

Fun weekly live Kanikapila every Monday

Fortnightly LIVE lessons

Your own personal ukulele tutor - ask questions anytime